

Trigger Handle /Triclamp design

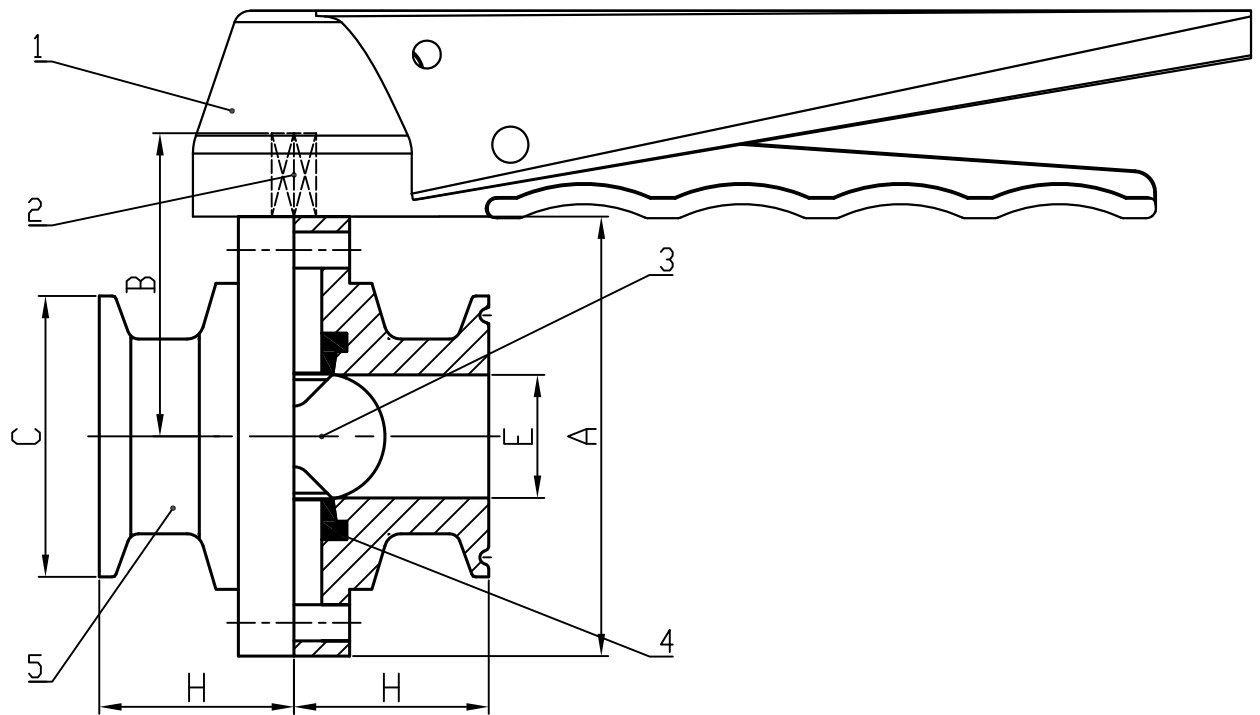

SIZE	A	B	C	E	H
1"	79	49.5	50.5	22.1	35
1.25"	79	49.5	50.5	29	35
1.5"	85	52.5	50.5	34.8	35
2"	100	60	64	47.5	37
2.5"	115	67.5	77.5	60.2	38
3"	127	73.5	91	72.9	39
3.5"	140	80	106	85	39
4"	156	88	119	97.6	45

5	Valve Flange		SS316L		
4	Rubber Seat		EPDM/Red Silicone/Transparent Silicone and Viton seat		
3	Disc		SS316L		
2	Disc Shaft		SS316L		
1	TRIGGER HANDLE		SS304		
No.	Name		Material		Note
	Trigger Handle /Triclamp design	Size: 1" to 4"	DATE	SS316L	Pitanco
DESIGN	X. cw				
CHECKED				WEIGHT	A4
		APPROVED			