

# Triclamp Butterfly valve with canister

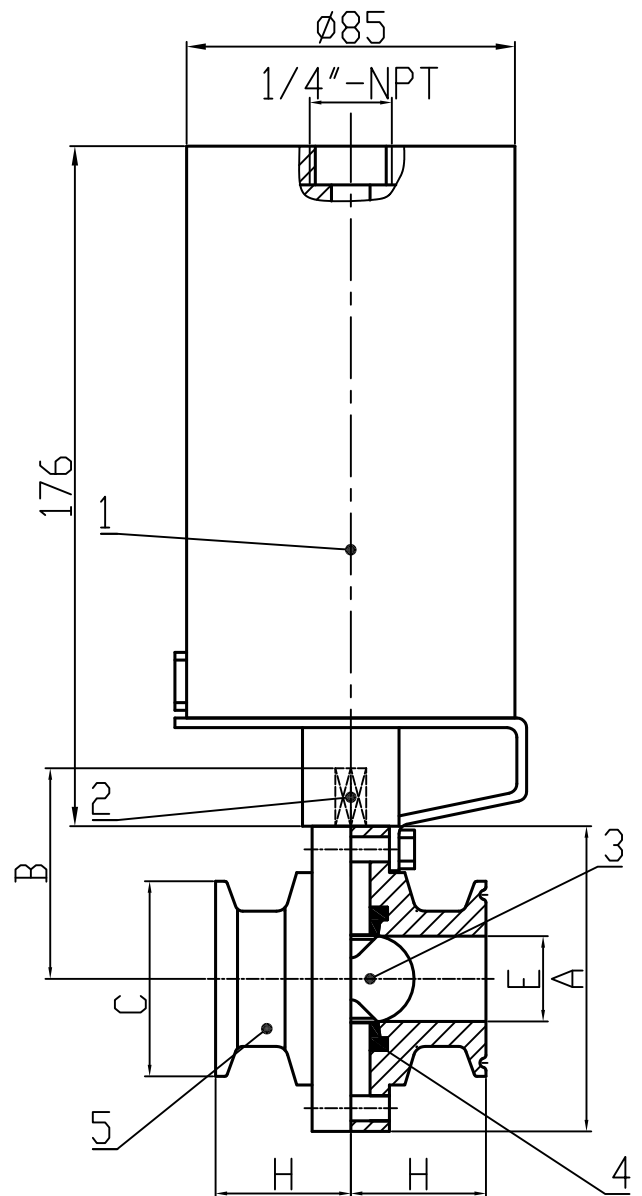

SIZE	A	B	C	E	H
1"	79	49.5	50.5	22.1	35
1.25"	79	49.5	50.5	29	35
1.5"	85	52.5	50.5	34.8	35
2"	100	60	64	47.5	37
2.5"	115	67.5	77.5	60.2	38
3"	127	73.5	91	72.9	39
3.5"	140	80	106	85	39
4"	156	88	119	97.6	45

5	Valve Flange			SS316L	
4	Rubber Seat			EPDM/Red Silicone/Transparent Silicone and Viton seat	
3	Disc			SS316L	
2	Disc Shaft			SS316L	
1	Pneumatic actuator			SS304	
No.	Name			Material	Note
	Pull Handle/ Triclamp design	Size: 1" to 4"	DATE	SS316L	Pitanco
	DESIGN				
	CHECKED				
			APPROVED	WEIGHT	A4